

VDPC series

Dynamic difference Pressure control Valves (DPCV)

Honeywell VDPC series of Dynamic Differential Pressure Control Valves (abbreviation: DPCV) have built-in dynamic differential pressure balancing sub-assembly is assembled by balancing plug, high performance membrane and spring. DPCVs apply to control the differential pressure (abbreviation: DP) between the inlet and outlet of a control valve or a branch pipe of air conditioning system in order to make the DP doesn't be impacted by central air conditioning system pressure changing and keep balancing, which can achieve valve or branch pipeline flow stability, improving the accuracy of valve regulation, eliminating the air conditioning terminal equipment temperature fluctuations and extending the service time of the control valve .

VDPC series of DPCVs usual work with static balancing valves to achieve total hydraulic balancing of the central air conditioning system.



Features

- High performance spring and membrane.
- Numeric handwheel for easy to set differential pressure.
- Segmented control DP design (high/low DP model) achieves higher DP control accuracy
- Convenient exhaust vent design for easy to exhaust air in the pipes.
- With useful accessory: pipe welding joints

Specification Parameters

Size	DN25-DN150	
PN	PN16	
Max working DP	DN25-DN50: 250kPa DN65~DN150: 350kPa	
Connection	DN25-DN50: Thread (BSPP) DN65~DN150: Flange (ISO7005-2)	
Medium	Applicable medium: Chilled water, Hot water, up to 50% Glycol water. (Medium standard: GB/T29044-2012) Temperature: -10...130 °C	
Materials	Body	DN25-DN50: Brass HPb59-1 DN65-DN150: GGG40
	Stem	SS304
	Plug	DN25-DN50: Brass HPb59-1 DN65-DN150: SS304
	Spring	SS304
	Membrane	EPDM with reinforced fibers

Specification Parameters

SKU	DN	PN	Kv Value m ³ /h	Setting DP range kPa	Connection
VDPC16R-025L	DN25	PN16	4.6	5~30	Thread
VDPC16R-025H	DN25	PN16	4.6	25~70	Thread
VDPC16R-032L	DN32	PN16	8.2	5~30	Thread
VDPC16R-032H	DN32	PN16	8.2	25~70	Thread
VDPC16R-040L	DN40	PN16	14	5~30	Thread
VDPC16R-040H	DN40	PN16	14	25~70	Thread
VDPC16R-050L	DN50	PN16	21.8	5~30	Thread
VDPC16R-050H	DN50	PN16	21.8	25~70	Thread
VDPC16F-065L	DN65	PN16	62	20~80	Flange
VDPC16F-065H	DN65	PN16	62	40~160	Flange
VDPC16F-080L	DN80	PN16	80	20~80	Flange
VDPC16F-080H	DN80	PN16	80	40~160	Flange
VDPC16F-100L	DN100	PN16	124	20~80	Flange
VDPC16F-100H	DN100	PN16	124	40~160	Flange
VDPC16F-125L	DN125	PN16	173	20~80	Flange
VDPC16F-125H	DN125	PN16	173	40~160	Flange
VDPC16F-150L	DN150	PN16	205	20~80	Flange
VDPC16F-150H	DN150	PN16	205	40~160	Flange

Flowrate performance

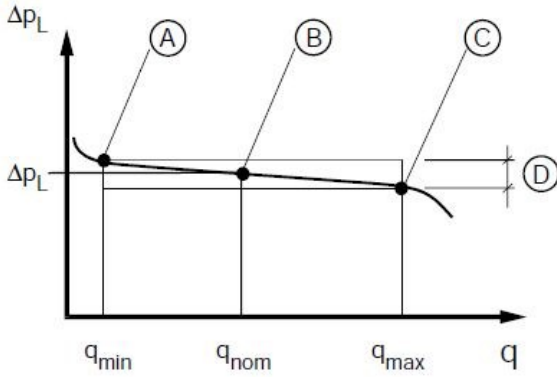

- A. q_{min}
- B. q_{nom}
- C. q_{max}
- D. DP control accuracy $\Delta p_L \pm 25\%$

ΔPL	5kPa			15kPa			20kPa			25kPa			30kPa		
DN	q_{min}	q_{nom}	q_{max}	q_{min}	q_{nom}	q_{max}	q_{min}	q_{nom}	q_{max}	q_{min}	q_{nom}	q_{max}	q_{min}	q_{nom}	q_{max}
25	0.12	1.02	1.38	0.25	1.68	2.25	0.31	1.94	2.74	0.35	2.31	3.24	0.42	2.52	3.53
32	0.22	1.79	2.53	0.27	2.84	4.06	0.32	3.28	4.86	0.41	3.85	5.42	0.48	4.35	6.14
40	0.26	2.84	4.03	0.45	5.23	7.23	0.52	6.14	8.42	0.61	6.85	9.14	0.69	7.32	10.2
50	0.46	4.62	6.32	0.63	8.21	11.4	0.71	9.54	13.2	0.82	10.6	14.9	0.92	11.5	16.2

ΔPL	25kPa			30kPa			40kPa			50kPa			60kPa			70kPa		
DN	q_{min}	q_{nom}	q_{max}	q_{min}	q_{nom}	q_{max}	q_{min}	q_{nom}	q_{max}	q_{min}	q_{nom}	q_{max}	q_{min}	q_{nom}	q_{max}	q_{min}	q_{nom}	q_{max}
25	0.32	2.33	3.27	0.44	2.56	3.57	0.54	2.93	4.18	0.59	3.37	4.72	0.68	3.64	5.12	0.76	3.96	5.52
32	0.34	4.11	5.46	0.46	4.54	6.24	0.63	5.14	7.16	0.78	5.73	8.06	0.83	6.32	8.93	0.91	6.81	9.45
40	0.53	7.06	9.75	0.56	7.62	10.4	0.67	8.65	12.2	0.82	8.83	13.9	1.09	10.5	14.9	1.02	11.6	15.9
50	0.75	10.8	14.9	0.84	11.8	16.3	0.98	13.7	19.1	1.13	15.0	21.0	1.35	16.9	22.9	1.56	17.9	24.8

ΔPL	20kPa			30kPa			40kPa			50kPa			60kPa			70kPa			80kPa		
DN	q_{min}	q_{nom}	q_{max}	q_{min}	q_{nom}	q_{max}	q_{min}	q_{nom}	q_{max}	q_{min}	q_{nom}	q_{max}	q_{min}	q_{nom}	q_{max}	q_{min}	q_{nom}	q_{max}	q_{min}	q_{nom}	q_{max}
65	1.08	18.6	29.3	1.15	20.5	31.5	1.27	23.1	34.2	1.44	25.2	38.8	1.65	28.2	43.2	1.78	31.25	47.2	1.91	33.2	50.7
80	1.35	26.3	37.2	1.42	31.4	41.2	1.53	34.6	46.8	1.72	37.8	51.8	1.91	40.2	55.2	2.14	42.2	60.8	2.35	45.6	63.8
100	2.86	38.2	63.4	3.01	43.1	68.8	3.32	46.3	76.4	3.54	50.7	83.5	3.65	53.5	89.4	3.86	56.4	94.2	3.74	60.2	100
125	4.31	59.2	92.4	4.52	61.4	102	4.75	74.6	106	4.96	83.7	121.4	5.24	92.3	130	5.53	99.6	140	5.76	108	150
150	6.01	79	120	6.35	88	131	6.65	99	143	6.92	110	158	7.35	119	171	7.65	128	185	7.94	140	199

ΔPL	40kPa			50kPa			60kPa			70kPa			80kPa			90kPa		
DN	q_{min}	q_{nom}	q_{max}	q_{min}	q_{nom}	q_{max}	q_{min}	q_{nom}	q_{max}	q_{min}	q_{nom}	q_{max}	q_{min}	q_{nom}	q_{max}	q_{min}	q_{nom}	q_{max}
65	1.3	25.3	36.4	1.46	27.2	39.2	1.64	29.6	44.4	1.81	31.8	48.2	1.93	33.2	50.7	2.15	36.5	56.4
80	1.55	35.1	47.5	1.74	38.2	52.2	1.92	40.9	56.8	2.15	42.7	60.3	2.34	45.8	64.2	2.52	47.3	68.4
100	3.35	45.3	76.6	3.55	50.7	83.6	3.65	53.5	89.4	3.86	56.4	94.2	3.79	60.3	101	3.85	65.9	112
125	4.83	75.2	112	5.04	84.2	122	5.36	94.6	130	5.54	102	140	5.76	110	151	5.94	113	160
150	6.53	104	145	6.93	113	160	7.35	124	179	7.65	131	181	8.01	141	203	8.35	148	215

ΔPL	100kPa			110kPa			120kPa			130kPa			140kPa			150kPa			160kPa		
DN	q_{min}	q_{nom}	q_{max}	q_{min}	q_{nom}	q_{max}	q_{min}	q_{nom}	q_{max}	q_{min}	q_{nom}	q_{max}	q_{min}	q_{nom}	q_{max}	q_{min}	q_{nom}	q_{max}	q_{min}	q_{nom}	q_{max}
65	2.35	38.2	60.2	2.53	40.2	64.3	2.65	41.9	68.4	2.71	43.2	70.3	2.83	46.2	72.5	2.94	47.8	74.2	3.11	49.2	76.5
80	2.76	49.6	72.3	2.94	51.2	75.8	3.12	52.5	78.3	3.35	54.6	80.3	3.54	56.7	84.5	3.74	58.5	87.8	3.92	60	91.5
100	3.97	69.5	124	4.13	74	128	4.25	77.2	134	4.35	86.5	141	4.55	84.4	148	4.75	87.9	148	5.2	90.1	153
125	6.21	119	168	6.42	122	174	6.88	126	180	7.21	130	186	7.42	134	192	7.65	139	196	7.84	143	203
150	8.63	154	220	8.97	158	228	9.27	163	234	9.52	168	240	9.84	178	247	10.4	175	253	10.7	178	258

Dimension and weight

DN25~DN50

DN	D (mm)	L (mm)	H (mm)	Weight (Kg)
DN25	98	100	170	2.45
DN32	98	102	175	2.62
DN40	98	115	180	2.99
DN50	98	125	185	3.37

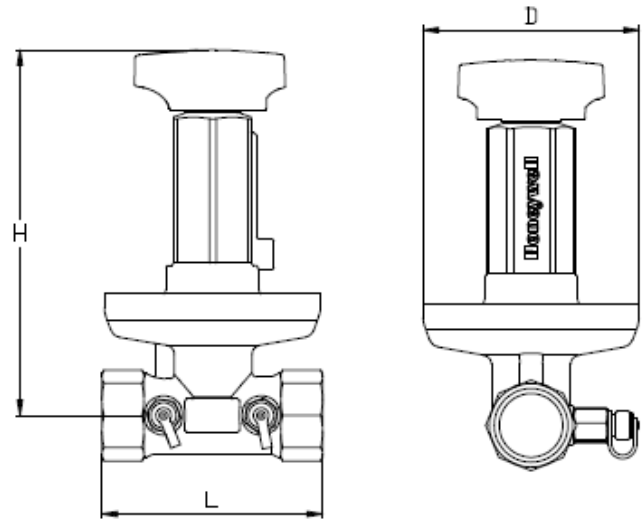

DN65~DN150

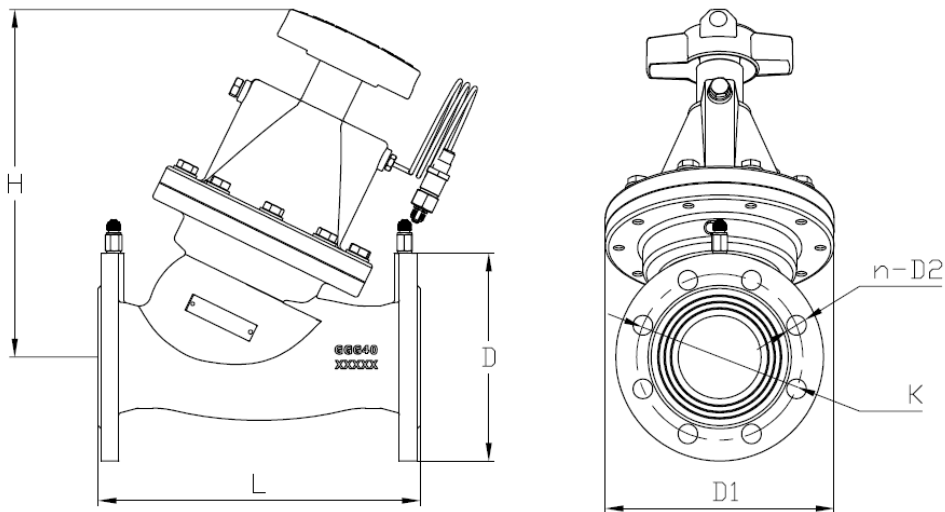

DN	L (mm)	D (mm)	D1 (mm)	n-D2 (mm)	K (mm)	H (mm)	Weight (Kg)
DN65	290	185	195	4-19	145	305	21.5
DN80	310	200	220	8-19	160	335	27
DN100	350	220	250	8-19	180	365	37
DN125	400	250	280	8-19	210	410	53
DN150	480	285	310	8-23	240	440	69

Installation and commissioning

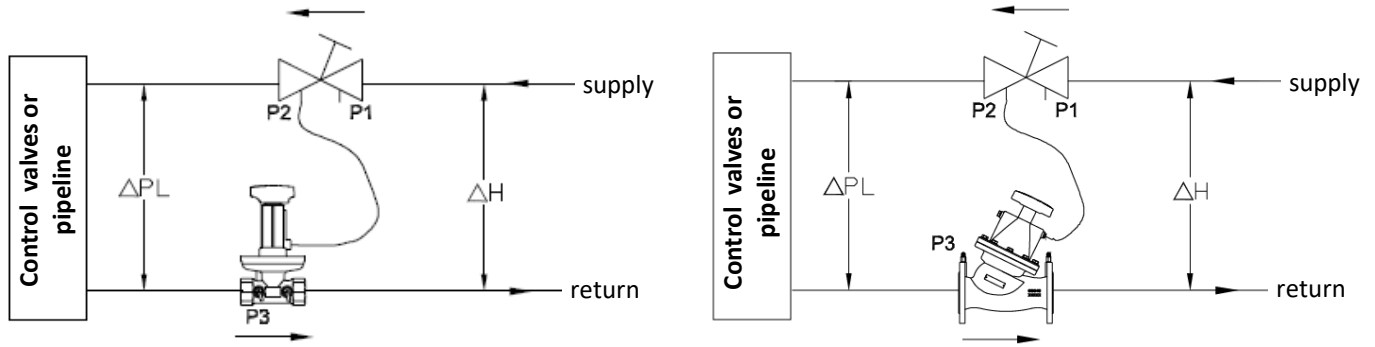

Tips: VDPC series DPCVs are usually installed on the return pipe, and pay attention to correct flow direction.

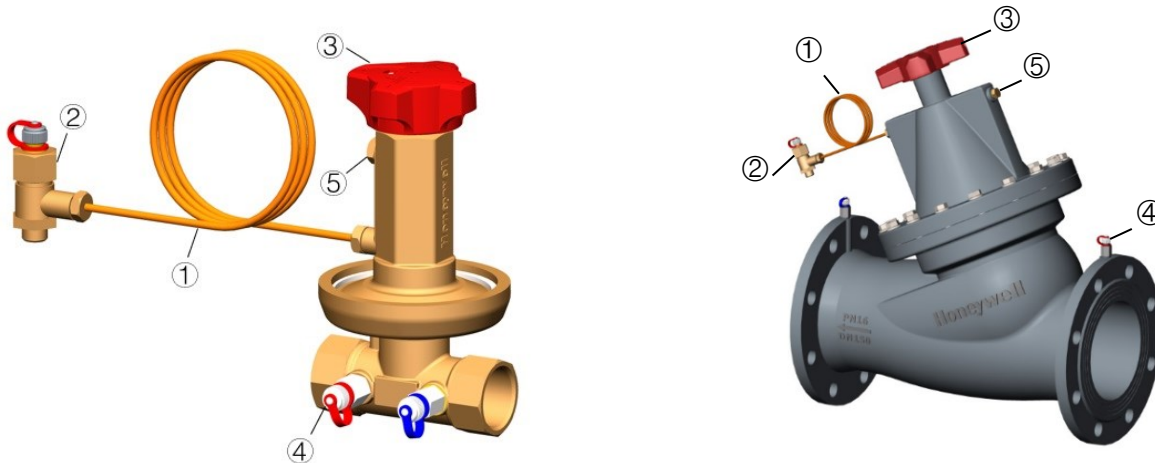

Commissioning

1. Connect the pressure pipe ①, as shown in the installation diagram, one end is connected to the DPCV, the other end is connected to the static balance valve through the tee measuring head ②, at this time the system should be in a low pressure state.
2. Open the vent plug ⑤, and then open the three-way measuring port ②, then water enters the pipeline. When all the air in the valve cavity is discharged, lock the vent plug ⑤.
3. Measure the DP between P2 and P3, namely ΔPL in the installation diagram shown above.
4. Set ΔPL : adjust the handwheel ③ to set the ΔPL .

Honeywell Environmental and Combustion Controls (Tianjin) Co., Ltd.

No. 158, Nanhai Road, Tianjin Economic-Technological Development Area

Postal Code: 300457

Tel: +86-22-66287000

Fax: +86-22-25325214

© 2020 Honeywell, all rights reserved.

These documents are subject to change without further notice.

THE
FUTURE
IS
WHAT
WE
MAKE IT

Honeywell